

# KLD-153XA

15inch Industrial Panel PC



## Features

- Aluminum die-casting chassis, fanless design
- 15inch LED TFT LCD, capacitive/resistive touch
- Intel Core 3rd Generation Processor
- 4\*COM, 2\*LAN, 4\*USB2.0
- AT & ATX Model
- Front Panel IP65 Level
- DC 9~36V power input optional

## Specifications

Processor	CPU	Intel® i3 3217U Dual Core up to 1.80 GHz 3M Cache, TDP 17W Intel® i5 3317U Dual Core up to 2.60 GHz 3M Cache, TDP 17W Intel® i7 3517U Dual Core up to 3.00 GHz 4M Cache, TDP 17W
	Cooling System	Fanless
	Memory	2xDDR3L, max 16GB
	Storage	mSATA SSD Full Size + 2.5inch HDD
Input Voltage	I/O ports	4xUSB2.0, Type A COM: 4 xRS232 , DB9, 2*RS485 optional Dual Display: 1xHDMI ( 1920*1080 @30Hz) 1*VGA (1920*1200 @30Hz) Audio: 1xMic in, 1x Line out WIFI: 802.11a/g/n, 2x2 Antenna, 2.4/5 GHz, 300 Mbps Max Speed
	Network(LAN)	2x Realtek 8111E, 10/100/1000Mbps Ethernet
	Input Voltage	12Vdc(Aviation Connector) , optional 9V 36V DC
LCD Display	Control SW/LED	1xPower SW, AT/ATX optional
	Display Type	15inch TFT LED Panel( LED Backlight)
Touchscreen	Max. Resolution	1024x768
	Luminance(cd/m <sup>2</sup> )	350nits
OS Support	Touch Type	5 wire Resistive Touch
	OS Support	Windows XP/ Windows 7/ Windows 8/ Windows 10/ Linux
Environment	Operating Temperature	-10°C,60°C(14~ 140 °F)(extend temperature optional)
	Storage Temperature	-20°C,70°C(-4 ~ 158°F)
	Front Panel Protection	IP65 compliant
Mechanical	Dimensions	(W*D*H): 358.3x282.2x69mm; Mounting Cut out (W*D): 337.3*261.2mm
	Weight	6.9KG
	Color	Black
	Material	Aluminum

## Pictures

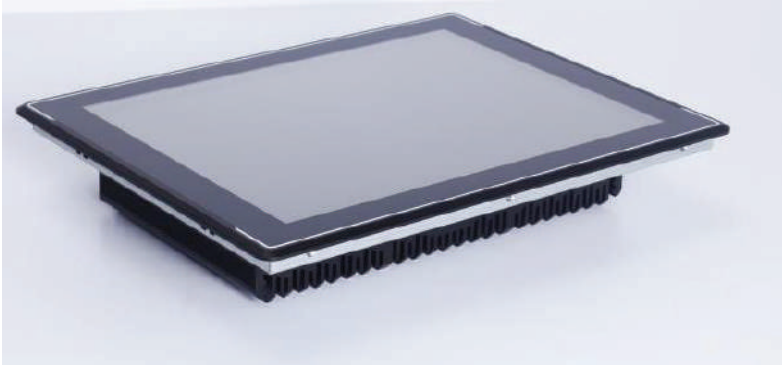

## Dimensions

Unit: mm

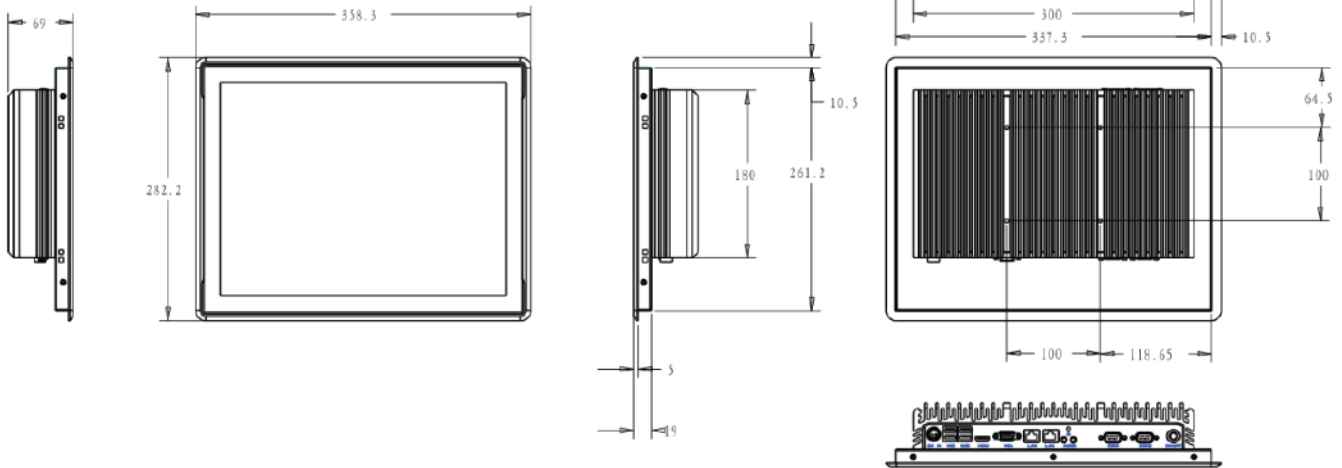

### Packing List

- 1x KLD-153XA
- 1x Driver CD
- 1x Power Adapter

### Operating Systems

- WIN7 32bit 64bit ENG
- WIN8 32bit 64bit ENG
- WIN10 32bit 64bit ENG
- Linux Ubuntu 12.04/16.04/18.04

### Ordering Information

- KLD-1531A: Resistive Touch Version
- KLD-1532A: Projected Capacitive Touch Version

### Optional accessories

- VESA Bracket
- Power Cable 2-pin 200cm